

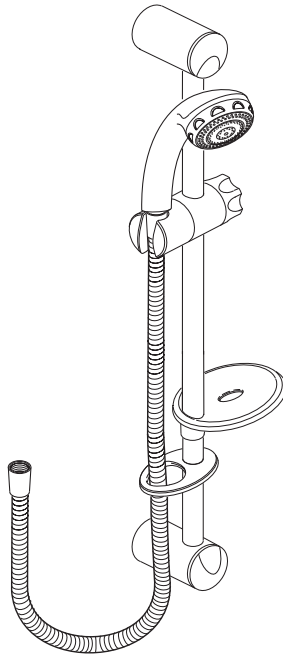

## *Autotherm-3*

**Rada Autotherm-3 Shower Fittings**

**Rada BSM Shower Fittings**



# PRODUCT MANUAL

## **IMPORTANT**

**Installer:** This Manual is the property of the customer and must be retained with the product for maintenance and operational purposes.

# CONTENTS

INTRODUCTION .....	3
IMPORTANT SAFETY INFORMATION .....	4
PACK CONTENTS CHECKLIST .....	5
SPECIFICATIONS .....	8
DIMENSIONS.....	10
INSTALLATION REQUIREMENTS.....	11
INSTALLATION.....	12
OPERATION.....	16
FAULT DIAGNOSIS .....	18
MAINTENANCE .....	19
SPARE PARTS .....	21
CUSTOMER CARE .....	Back Cover

If you experience any difficulty with the installation or operation of your new shower fittings, then please refer to FAULT DIAGNOSIS, before contacting Kohler Mira Limited. Our telephone and fax numbers can be found on the back cover of this guide.

# INTRODUCTION

Thank you for purchasing a quality Rada product. To enjoy the full potential of your new product, please take time to read this guide thoroughly, having done so, keep it handy for future reference. The following shower fittings are covered by this guide:

## **Rada Autotherm-3 EV Shower Fitting**

An adjustable spray handset with three different spray actions (start, force, soothe), and an economy setting\*, supplied complete with flexible hose, clamp bracket assembly, slide bar, supports, soap dish, two parking sockets and hose retaining ring. Suitable for connection to surface mounted shower controls. Available in chrome finish.

The adjustable spray handset is supplied with a low capacity spray plate fitted, a high capacity plate is also supplied.

## **Rada Autotherm-3 EV CAT 5 Shower Fitting**

Designed to comply with the requirements of a Fluid Category 5 risk installation (as detailed in Water Regulations). As above but with special patented Security Hose Retaining Ring\*\* which replaces the standard hose retaining ring and no parking sockets.

\* The economy setting reduces the water flow to give economical use of water, whilst still giving an adequate shower performance. This setting performs best with most gravity, pumped, and mains pressure unvented systems. On electric showers and some combination boiler systems the economy setting will have no effect, and will give the same spray action as the start setting.

\*\*The security hose retaining ring for use with Category 5 risk installations is permanently connected to the hose. It allows the hose to move through it for showering, but complete withdrawal of the hose is prevented.

## **Rada BSM Shower Fitting**

An adjustable spray handset, with three different spray actions. Supplied complete with flexible hose, clamp bracket assembly, slide bar, hose retainer and supports.

# IMPORTANT SAFETY INFORMATION

## Warning!

Products manufactured by us are safe provided they are installed, used and maintained in good working order in accordance with our instructions and recommendations.

## Caution!

1. Read all of these instructions and retain this guide for later use.
2. Pass on this guide in the event of change of ownership of the installation site.
3. Follow all warnings, cautions and instructions contained in this guide.
4. Anyone who may have difficulty understanding or operating the controls of any appliance should be attended whilst operating. Particular consideration should be given to the young, the elderly, the infirm, or anyone inexperienced in the correct operation of the controls.

# PACK CONTENTS CHECKLIST

## Rada Autotherm - 3 EV Shower Fittings

Tick the appropriate boxes to familiarize yourself with the part names and to confirm that the parts are included.

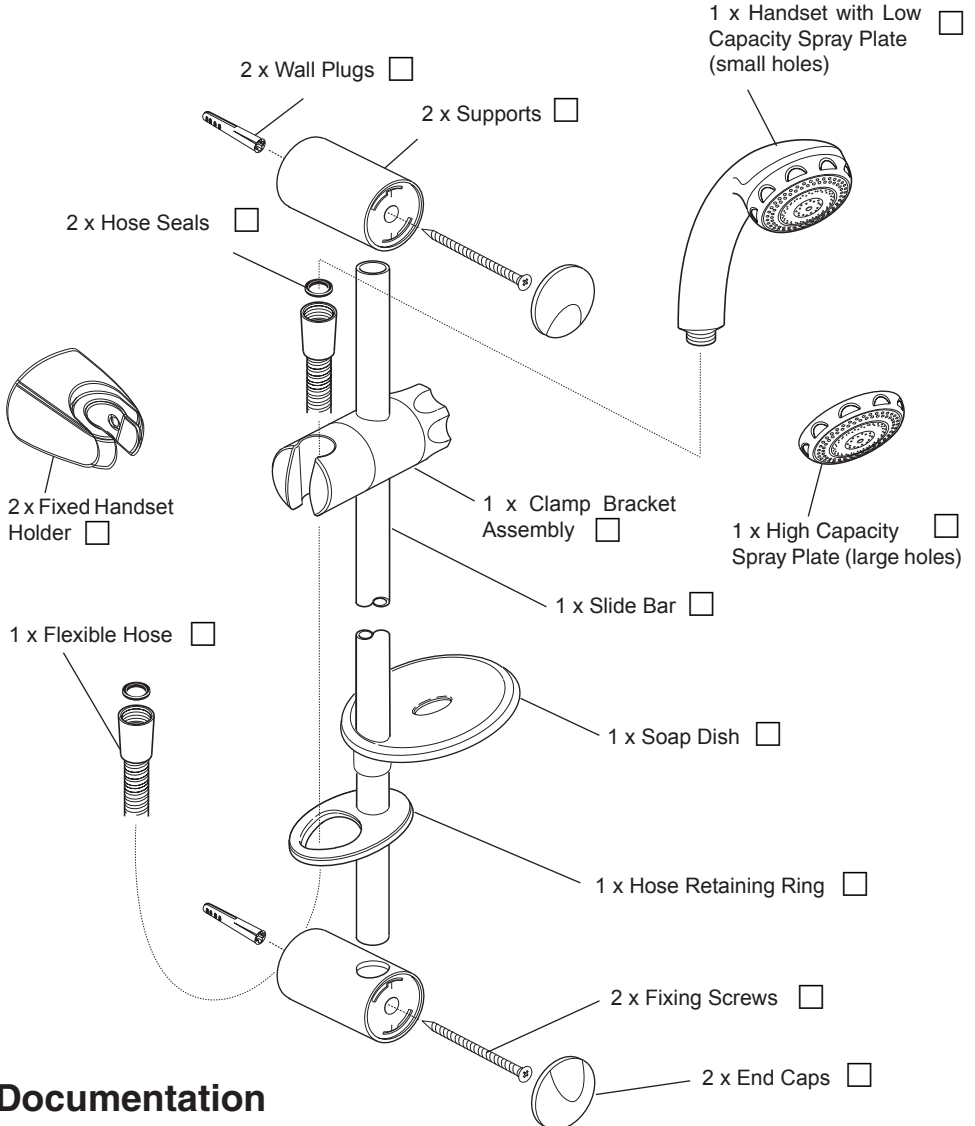

## Documentation

1 x Product Manual

# PACK CONTENTS CHECKLIST

## Rada Autotherm-3 EV (CAT 5) Shower Fittings

Tick the appropriate boxes to familiarize yourself with the part names and to confirm that the parts are included.

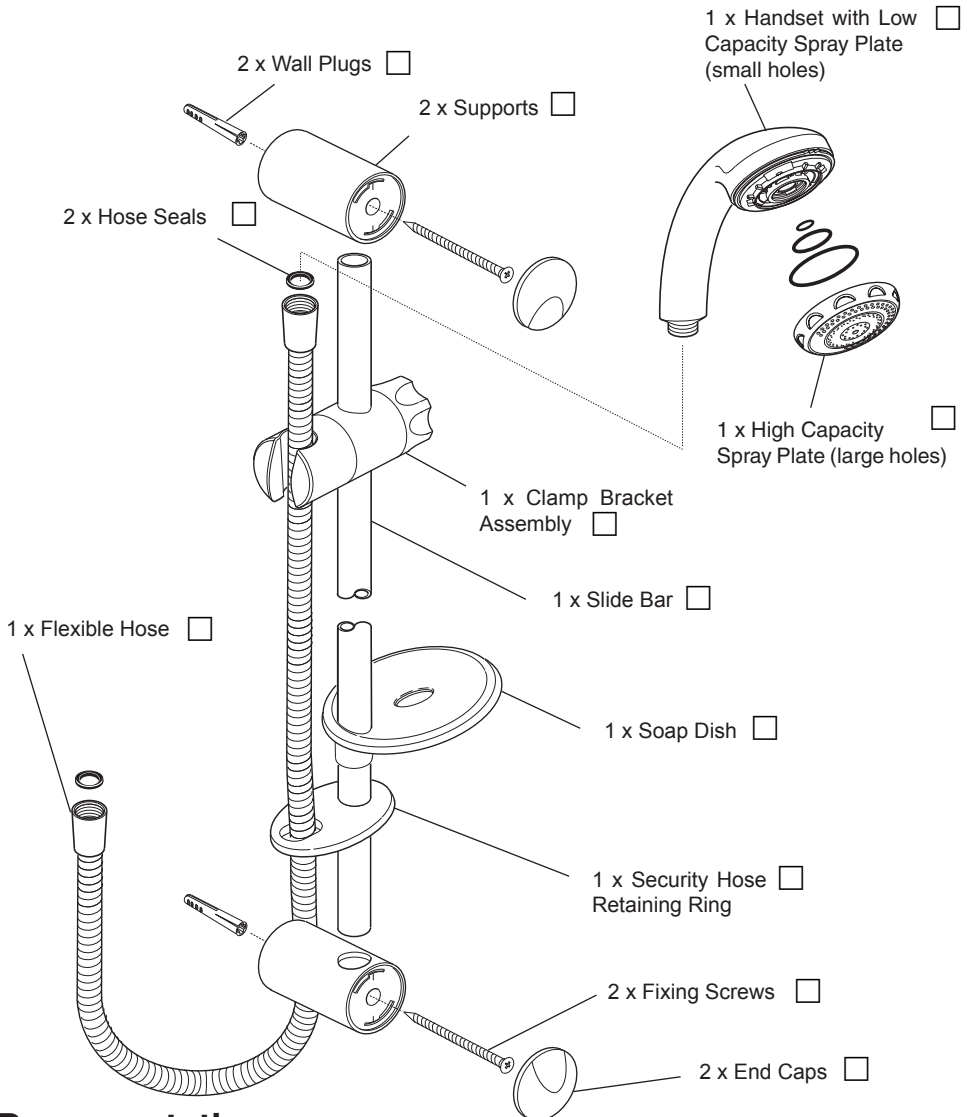

## Documentation

1 x Product Manual

# PACK CONTENTS CHECKLIST

## Rada BSM Shower Fittings

Tick the appropriate boxes to familiarize yourself with the part names and to confirm that the parts are included.

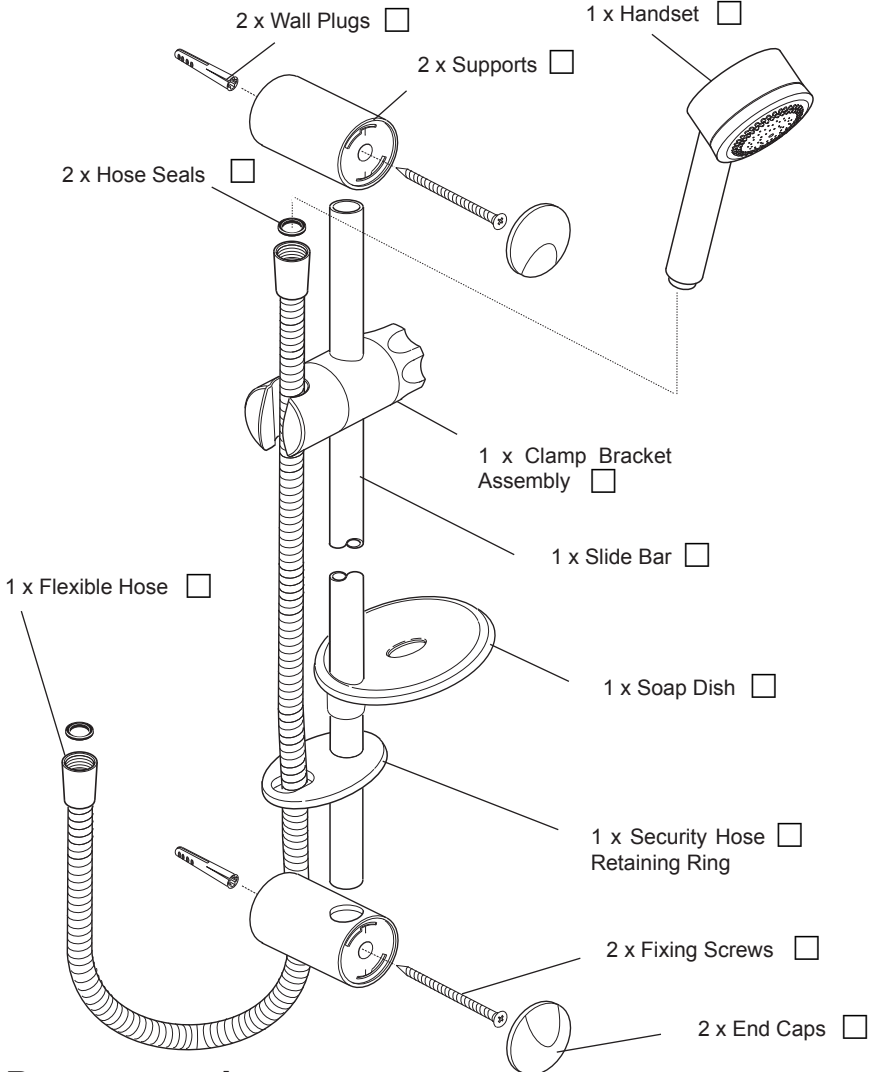

## Documentation

1 x Product Manual

# SPECIFICATION

## Shower Fittings Flow Performance Graphs

### Rada Autotherm-3 EV range flow rates - Low capacity spray plate assembly

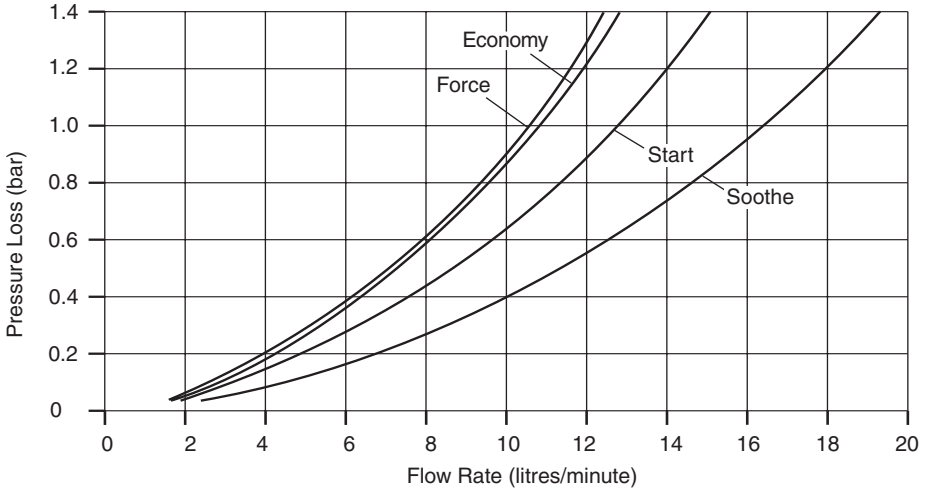

### Rada Autotherm-3 EV range flow rates - High capacity spray plate assembly

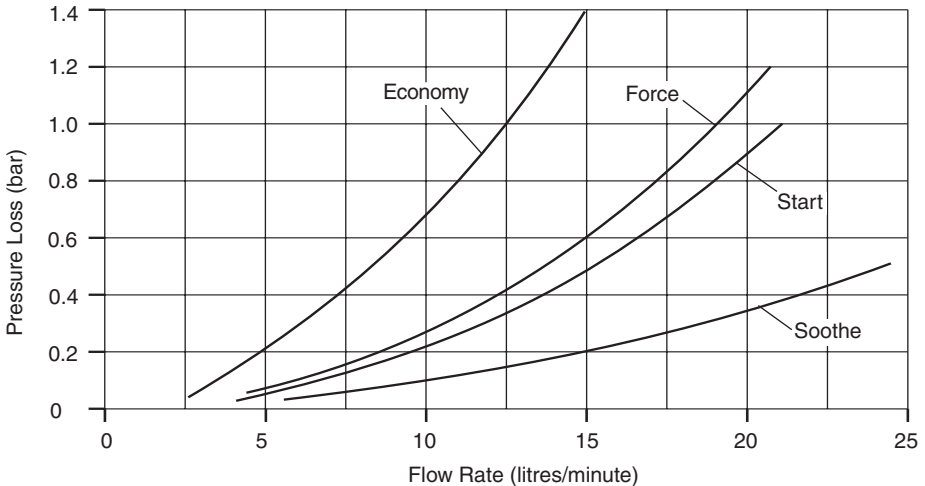

These are the typical pressure loss graphs for the Autotherm range of shower fittings. There will also be an additional pressure loss through the shower control and outlet hose/pipework (Pressure loss = Pressure difference between the inlet and outlet of the fitting).



# Shower Fittings Flow Performance Graphs

Rada BSM Shower Fittings range flow rates - Low capacity spray plate assembly

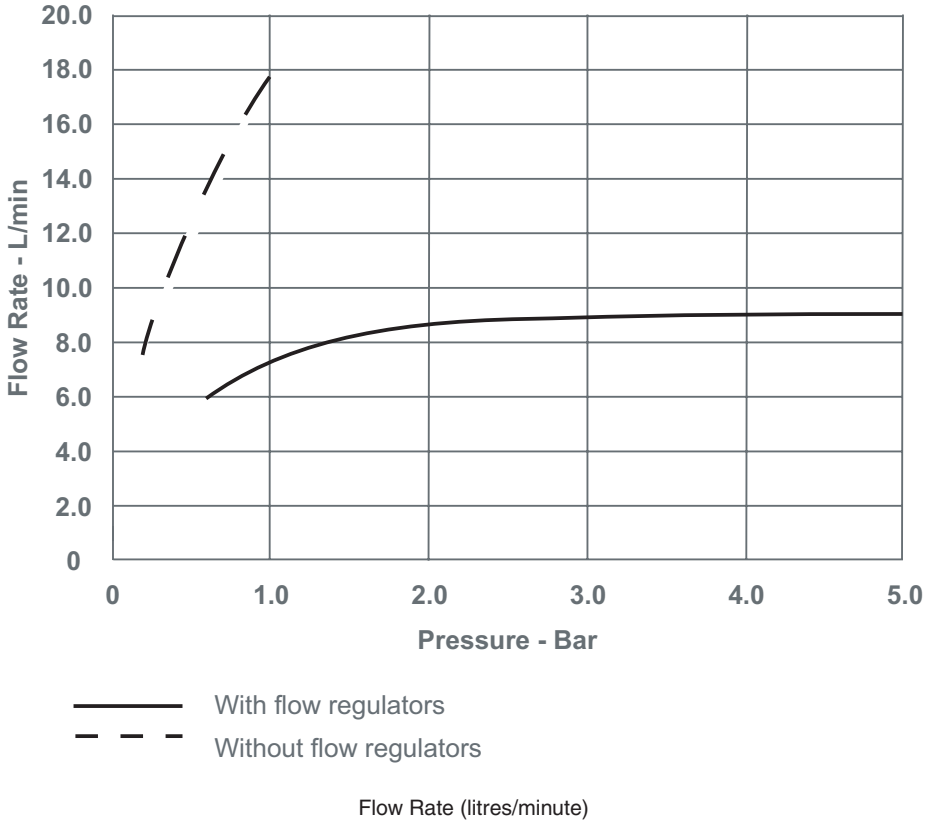

These are the typical pressure loss graphs for the Autotherm range of shower fittings. There will also be an additional pressure loss through the shower control and outlet hose/pipework (Pressure loss = Pressure difference between the inlet and outlet of the fitting).

## Rada BSM Shower Fittings Inlet Pressures

Minimum maintained pressure: **0.05 bar**.

Maximum maintained pressure: **5.0 bar**.

## Rada Autotherm-3 EV Shower Fittings Inlet Pressures

Minimum maintained pressure with flow regulators removed: **0.2 bar**.

Maximum maintained static pressure: **7.0 bar**.

Maintained pressures above the stated maximum could result in excessive spray forces and possible damage to the product.

The high capacity spray plate should be fitted if the maintained inlet pressures at the shower control are above 0.9 bar. For some gas water heater installations fitting the high capacity spray plate is recommended.

## DIMENSIONS

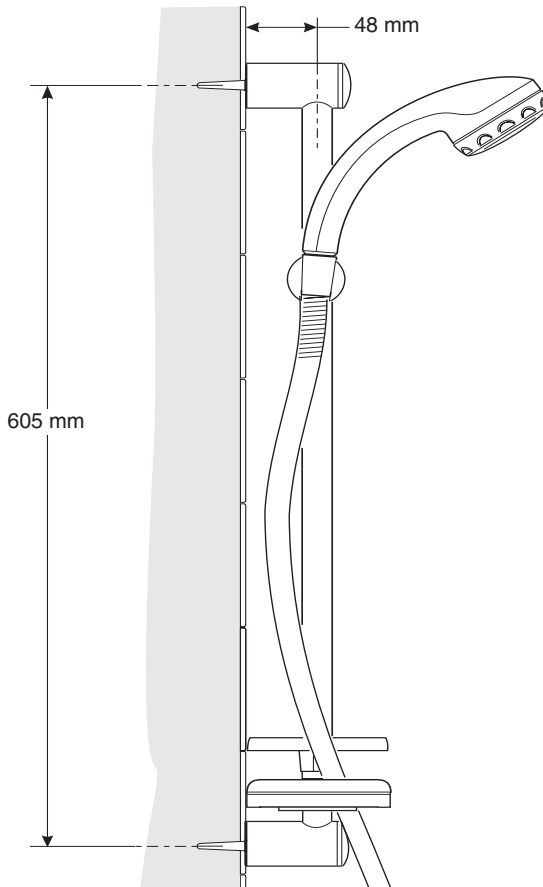

# INSTALLATION REQUIREMENTS

## General

**Installation must be carried out in accordance with these instructions, and must be conducted by designated, qualified and competent personnel.**

1. Before connecting the shower fitting the supply pipework **MUST** be flushed to clear debris.
2. A hose retaining ring is supplied to prevent the handset from dropping below the spill-over level of the bath or shower, which could lead to contamination from back-siphonage. For category 5 installations, the category 5 fittings set **MUST** be used.
3. Installations **MUST** comply with all the Local and National Water Supply Authority Regulations and Byelaws (Scotland), Building and Plumbing Regulations in force at the time of installation. The installation should be carried out by a plumber or contractor who is registered, or is a member of, an association such as:
  - Institute of Plumbing (IOP), throughout the UK.
  - National Association of Plumbing, Heating and Mechanical Services Contractors (NAPH & MSC), England and Wales.
  - Scottish and Northern Ireland Plumbing Employers' Federation (SNIPEF), Scotland and Northern Ireland.
4. When installing the shower fittings in a cubicle, it is best positioned to spray across rather than towards the opening of the cubicle.
5. Avoid layouts where the shower hose will be sharply kinked. This may reduce the life of the hose.
6. **Do not** use excessive force when making connections.
7. **Do not** install the shower fitting in a position where it could become frozen.
8. **Do not** fit any form of flow control in the outlet pipework if the shower fitting is installed in conjunction with a product that requires the fitting to act as a vent (e.g. an electric shower).
9. Layout and sizing of pipework should be such that when other services are used, pressures do not fall below the recommended minimum for the shower fitting as this will cause the spray pattern to collapse.
10. For a gravity fed shower installation, the minimum pressure at the shower fitting is 0.06 bar. To generate the minimum pressure and accommodate the pressure loss in the pipes and shower control, a head of water of 1.5 metre is required on a typical correct installation.
11. The shower fitting is connected to the bottom outlet of the shower control or shower outlet of the bath shower mixer as appropriate.

# INSTALLATION

Read the section **INSTALLATION REQUIREMENTS** first.

The slide bar should be fixed to the wall to one side of the shower control, at a convenient height for all the family. It should be positioned so that the handset discharges down the centre line of the bath, or across the opening of a shower cubicle and should be directed away from the shower control. For category 5 installations the security hose retaining ring **MUST** be used.

## Solid, dry-lined, stud partition, shower cubicle or laminated panel walls

1. Decide on a suitable position for the slide bar avoiding buried cables and pipes. Make sure that when the hose retaining ring is placed in the lowest position on the slide bar, there is a minimum of 40 mm between the handset and bath/tray spill-over level.

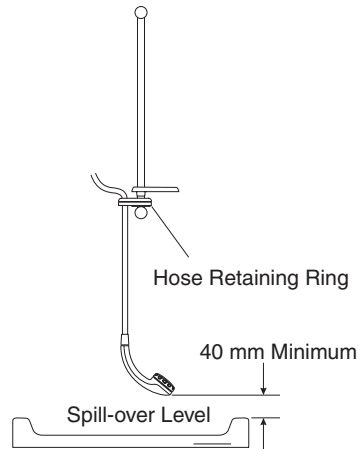

2. For category 5 installations, secure the lower slide bar support a minimum 730 mm above the top of the bath spill-over level, avoiding any buried cables and pipes. Make sure there is a minimum of 40 mm between the handset and top of the bath spill-over level. This is to prevent back-siphonage.

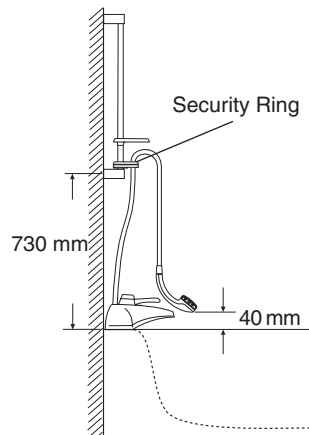

3. Drill two 7.0 mm holes at 607 mm centres, avoiding any buried cables or pipes, and fit the wall plugs supplied.

**Note!** Installers may wish to obtain alternative proprietary cavity fixings, when installing on to a dry lined, stud partition, shower cubicle or laminated panel wall structures. However, these methods of fixing are beyond the scope of this guide.

4. Assemble the clamp bracket components.
5. Push the slide bar through the clamp bracket assembly. Push the soap dish and the hose retaining ring onto the bottom of the slide bar. For category 5 installations the security hose retaining ring is already attached to the hose.
6. Insert the fixing screw into the hole of the slide bar support. Fit the bottom slide bar support loosely to the wall to make aligning the top support easier. Push the slide bar into the support.
7. Push the slide bar into the support. Place the screw through the top support and fully tighten.
8. Fully tighten the bottom support.
9. Fit the end caps over the ends of the slide bar supports.
10. Screw the hose onto the outlet of the shower control, or the right angled connector (Make sure that the hose seal is fitted). **Do not overtighten** (hand tight should be sufficient).
11. Pass the flexible hose through the hose retaining ring (category 3 only) and screw the remaining end of the hose onto the handset (Make sure that the hose seal is fitted).
12. Place the handset into the slide bar clamp bracket.

**Note!** The clamp bracket is tapered. The handset will only fit properly from one direction. If necessary turn the end of the clamp bracket until the handset will fit.

The clamp bracket has a central securing screw which can be tightened to increase the friction lock and prevent the handset from pivoting downwards.

## Install the Parking Socket

1. Decide on a suitable location for the parking socket avoiding buried cables and pipes.

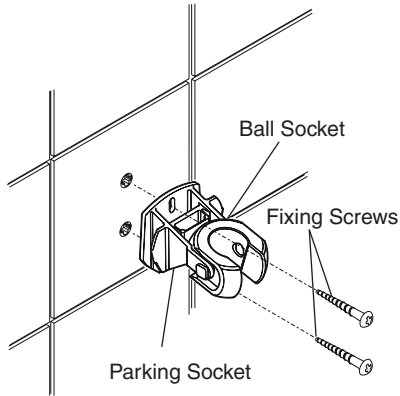

2. Hold the parking socket on the wall and mark the positions of the fixing holes.

3. Drill the 8mm holes for the fixing screws and insert the wall plugs (supplied).

**Note!** Alternatively use proprietary cavity fixings for dry lined, stud partition, shower cubicle or laminated panel walls.

4. Secure the parking socket on the wall with the fixing screws (supplied).

**Note!** You may find it easier to remove the ball socket to secure screws and then re-fit.

5. Clip on the parking socket cover .

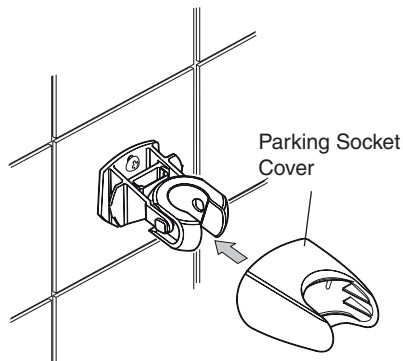

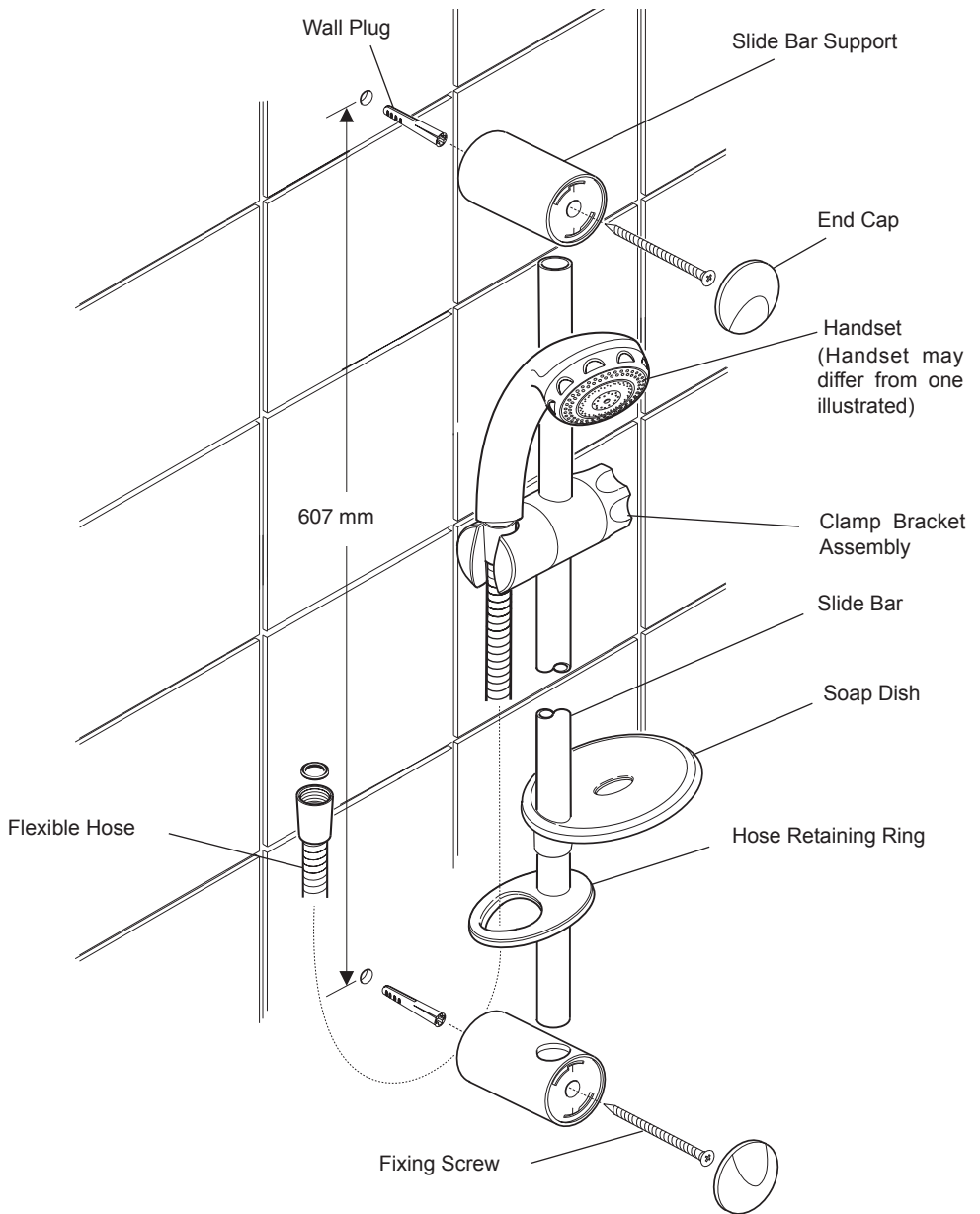

# OPERATION

## Spray Action - Rada Autotherm-3 Fittings

The handset spray head has three different spray actions (start, soothe and force) and economy setting.

### 1. Economy Setting

Turn the spray plate fully clockwise. Water will flow from the outer set of holes and the flow rate will be reduced.

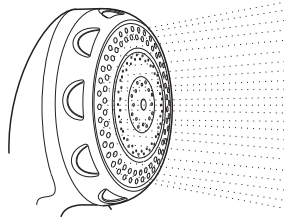

### 2. Start

Turn the spray plate anticlockwise until it 'clicks' (one click from economy setting). Water will flow from the outer set of holes.

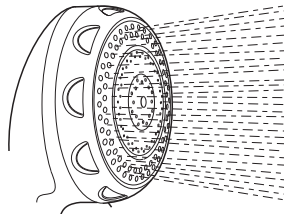

### 3. Soothe

Turn the spray plate anticlockwise until it 'clicks' (two clicks from economy setting). Water will flow from the middle set of holes.

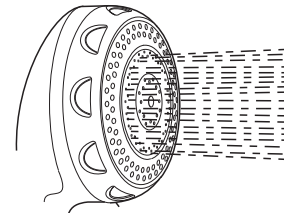

### 4. Force

Turn the spray plate anticlockwise until it 'clicks' (three clicks from economy setting). Water will flow from the inner set of holes.

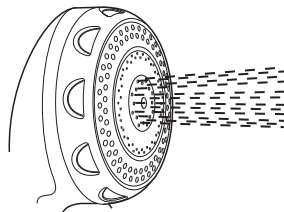



# OPERATION

## Spray Action - Rada BSM Fittings

The handset spray head has four different spray actions: Eco, Start, Soothe and Force. The handset operation is described below.

### 1. Eco

To access the eco setting, turn the spray plate fully clockwise. Water will flow from the outer set of holes and the flow rate will be reduced.

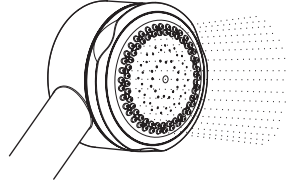

### 2. Start

To access the start setting turn the spray plate anticlockwise until it 'clicks' (one click from the eco setting). Water will flow from the outer set of holes.

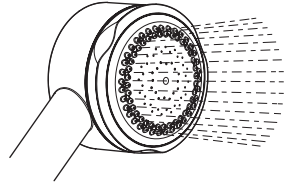

### 3. Soothe

To access the soothe setting turn the spray plate anticlockwise until it 'clicks' (two clicks from the eco setting). Water will flow from the large diameter holes.

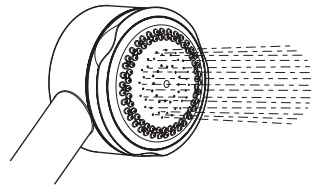

### 4. Force

To access the force setting turn the spray plate anticlockwise until it 'clicks' (three clicks from the eco setting). Water will flow from the inner set of holes.

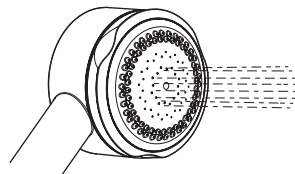

# FAULT DIAGNOSIS

Providing the shower fittings have been correctly installed and are operated in accordance with the instructions contained in this guide, difficulties should not arise. If any maintenance is required then it must be carried out by a competent tradesperson for whom the fault diagnosis chart and maintenance instructions are provided. Before replacing any parts ensure that the underlying cause of the malfunction has been resolved.

Malfunction	Cause	Remedy
No flow or low flow rate from shower fittings.	Spray plate blocked.  Hose blocked, twisted or damaged.	Refer to <b>MAINTENANCE, "Cleaning"</b> . Clear blockage, release twist in hose or renew hose.
Drip from spray plate assembly in handset.	A small amount of water may be retained in the shower fitting after the shower control has been turned off. This may drain over a few minutes.  Defective seal(s) in the shower control.	This is quite normal. Changing the angle of the shower fitting may vary the draining time.  Refer to shower control Instruction Manual.
Shower handset will not lock in any position.	The clamp bracket has a central screw that has become slack.	Tighten the central securing screw to increase the friction lock and prevent the handset from pivoting downwards.

# MAINTENANCE

## Spray Plate Assembly - Removal and Installation

The procedure for the removal and installation of the spray plate assembly is identical for both the handset and the bir assembly. The handset procedure is described below.

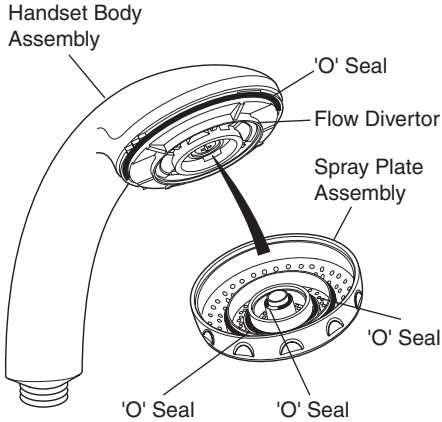

### Removal

1. Turn the adjuster ring fully anticlockwise.
2. Unscrew the spray plate in an anticlockwise direction. The 'O' seals will provide some resistance.

### Installation

3. Make sure that the four 'O' seals are located correctly.
4. Turn the flow divertor fully clockwise.

**Caution!** Do not over tighten the spray plate.

5. Carefully screw the spray plate assembly on to the flow divertor. The 'O' seals will resist the rotation of the spray plate.

## Spray Plate Cleaning

Many household cleaners contain abrasives and chemical substances, and should not be used for cleaning plated or plastic fittings. These finishes should be cleaned with a mild washing up detergent or soap solution, and then wiped dry using a soft cloth.

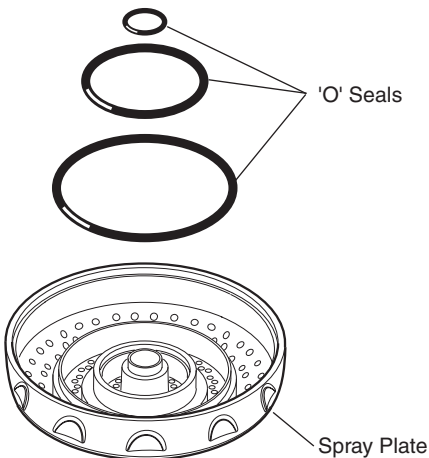

1. Unscrew and remove the spray plate assembly.
2. Remove the 'O' seals.
3. Clean all the components with a stiff brush. If necessary use a plastic kettle descaler in accordance with the manufacturer's instructions. Flush thoroughly with water before the shower is used.
4. Refit the components in reverse order.
5. Install the spray plate assembly.

## Handset spray plate - external

1. Use your thumb or a soft cloth to wipe any limescale from the soft nozzles and the front surface of the handset spray plate.

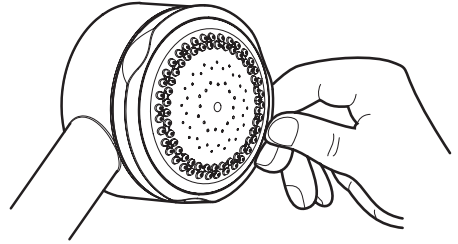

# SPARE PARTS

## Rada Autotherm - 3 EV Spare Parts List

- 411.37 Service Pack 'O' Seals - components identified 'A'
- 462.20 Rada Handset - chrome
- 462.21 1.5 m Hose - chrome - Category 3
- 462.22 1.5 m Hose Assembly - Chrome - Category 5
- 617.05 Spray Plate - HC and LC - chrome
- 617.06 Slide Bar Support Assembly - chrome - components identified 'B'
- 617.08 Slide Bar - chrome
- 617.09 Soap Dish - chrome
- 617.10 Hose Retaining Ring - chrome
- 617.11 Clamp Bracket Assembly - chrome

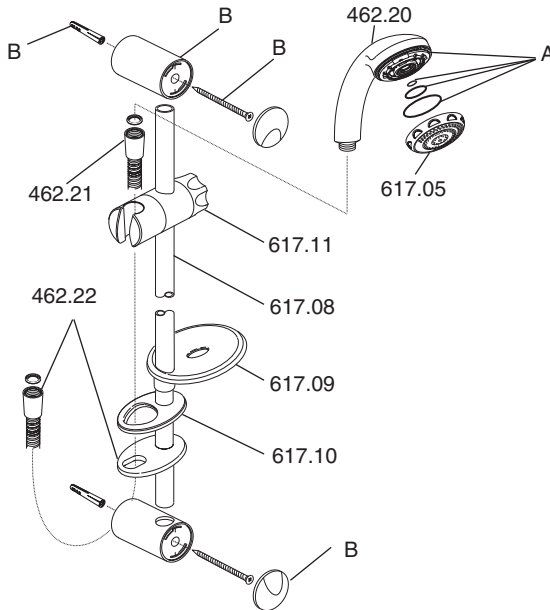

# Rada BSM Shower Fittings - Spare Parts List

- 1595.030 Handset
- 1595.031 Adjuster Ring
- 1595.032 Spray Plate

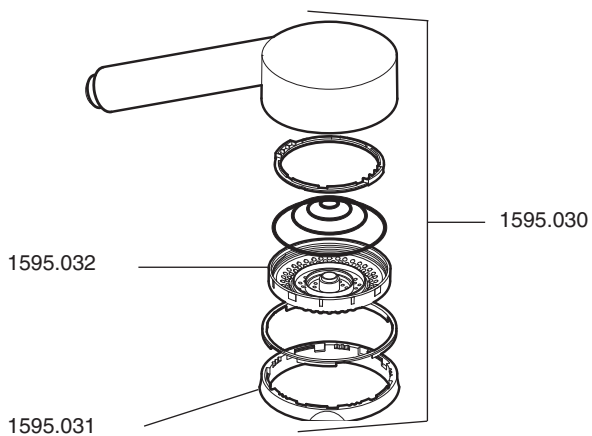

# NOTES

# CUSTOMER SERVICE

## Guarantee

Your product has the benefit of our manufacture's guarantee which starts from date of purchase. Within the guarantee period we will resolve defects in materials or workmanship, free of charge, by repairing or replacing parts or product as we may choose.

**This guarantee is in addition to your statutory rights and is subject to the following conditions:**

- The product must be installed and maintained in accordance with the instructions given in this user guide.
- Servicing must only be undertaken by us or our appointed representative. **Note!** If a service visit is required the product must be fully installed and connected to services.
- Repair under this guarantee does not extend the original expiry date. The guarantee on any replacement parts or product ends at the original expiry date.
- For shower fittings or consumable items we reserve the right to supply replacement parts only.

**The guarantee does not cover:**

- Call out charges for non product faults (such as damage or performance issues arising from incorrect installation, improper use, inappropriate cleaning, lack of maintenance, build up of limescale, frost damage, chemical attack, corrosion, system debris or blocked filters) or where no fault has been found with the product.
- Water or electrical supply, waste and isolation issues.
- Compensation for loss of use of the product or consequential or indirect loss of any kind.
- Damage or defects caused if the product is repaired or modified by persons not authorised by us or our appointed representative.
- Routine maintenance or replacement parts to comply with the requirements of the TMV2 or TMV3 healthcare schemes
- Accidental or wilful damage.
- Products purchased ex-showroom display.

## What to do if something goes wrong

If your product does not work correctly refer to this manual for fault diagnosis and check that it is installed and commissioned in accordance with our instructions. If this does not resolve the issue, contact us for help and advice.



## Technical Helpdesk Service

Contact our Customer Services Team for product advice, to purchase spare parts or accessories or to set up service visit. You can contact us via phone or e-mail - contact details below. Please provide your model name, power rating (if applicable) and date of purchase.



## Rada Website ([www.radacontrols.com](http://www.radacontrols.com))

From our website you can view our full product catalogue or download a brochure.



## Spares and Accessories

We hold the largest stocks of genuine Rada spares and accessories.



## Service/Repairs

No one knows our products better than our nationwide team of Service Technicians. We can carry out service or repair work to your product both during and after the guarantee period. You have the assurance of a fully trained Technician, genuine Rada spare parts and a 12 month guarantee on any chargeable work done.

## Service Contracts

Regular servicing ensures your product continues to operate at the peak of performance. We offer annual or bi-annual servicing carried out by our fully trained technicians subject to site survey

## To Contact Us - UK Customer Service & Specification Enquiries



**0844 571 1777**

Calls cost 7p per minute plus your phone company's access charge



**Fax: 0844 472 3076**



Email – Visit

[rada\\_technical@mirashowers.com](mailto:rada_technical@mirashowers.com)



By Post: Rada Controls, Cromwell Road, Cheltenham, Gloucestershire GL52 5EP

## To Contact Us: Eire Only



**01 531 9337**



E-mail:

[CustomerServiceEire@mirashowers.com](mailto:CustomerServiceEire@mirashowers.com)

*Rada is a registered trade mark of Kohler Mira Limited.*

*The company reserves the right to alter product specifications without notice.*



**rada**